

North America

Servers and Data Centers protection and monitoring solutions

Controls

Solutions

From servers to Data Centers

■ Data Centers, a battle between growth and efficiency

As the world becomes increasingly digitized, information and communications, technology is emerging as an important source of electricity demand. Billions devices and machines are already connected, and more will be connected over the coming years, using electricity directly and fuelling growth in demand for data center and transmission network services.

Electricity demand in the world's data centers in 2019 amounted to 200 TWh, about 1% of the global electricity demand. While IP traffic and workloads are projected to triple in near terms, global data center electricity demand is expected to remain flat up to 2022 based on efficiency trends, see the graph below.

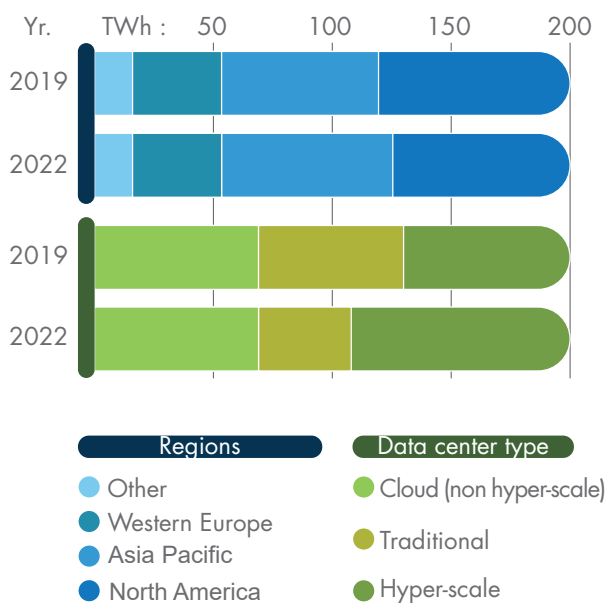

Font: IEA, World Energy Outlook 2020

The strong growth in demand for data center services is offset by continued improvements to servers, storage devices, network switches and data center infrastructure as well as a shift to much larger shares of highly efficient cloud and hyper-scale data centers supported by the use of artificial intelligence and machine learning that will reduce the energy intensity of data center services even more.



■ 5 good reasons to have a critical power & data center monitoring solution:

1. because it is an energy-intensive user (usually more than 20MW for large data centers);
2. because it has to provide a 99.9% up-time (equivalent to 364.3 uptime days);
3. because the most overlooked elements are power utilization, consumption and monitoring;
4. because making the right decisions can improve server health and data center efficiency;
5. because you can't effectively manage something you can't monitor. The only way to run a properly optimized data center is to have a solid monitoring platform designed for your environment.

■ Avoid unplanned downtime costs

According to a survey made in the USA (the largest data center market) by the Ponemon Institute, the average cost per minute of unplanned data center downtime is 5,900 USD. A significant cost which can be avoided using a proper monitoring solution.

The data center industry is using different technical solutions and installation technologies, depending on the number of servers, where the most important goal is always, directly or indirectly, the streamlining of costs and the maximizing of savings. The following list shows you the different individual or combined approaches:

- the **"prefabricated modular data center"** where the aim is the short deployment timeframe and improved predictability of performance;
- the **DCIM "Data Center Infrastructure Management"** where the set of tools that help to organise and manage the infrastructure and the PUE (Power Usage Effectiveness) is a measure of how efficiently a data center uses energy;
- the **"green data center"** where the maximum energy efficiency and minimum environmental impact is the goal.

Monitoring

The map

■ The Carlo Gavazzi protection and monitoring map

This map guides you, in this example, through the Carlo Gavazzi competences and product solutions. A journey through protections, core units, utility meters data acquisition and integration solutions. But also integration of main, sub-metering and high density metering systems in existing and new installations!

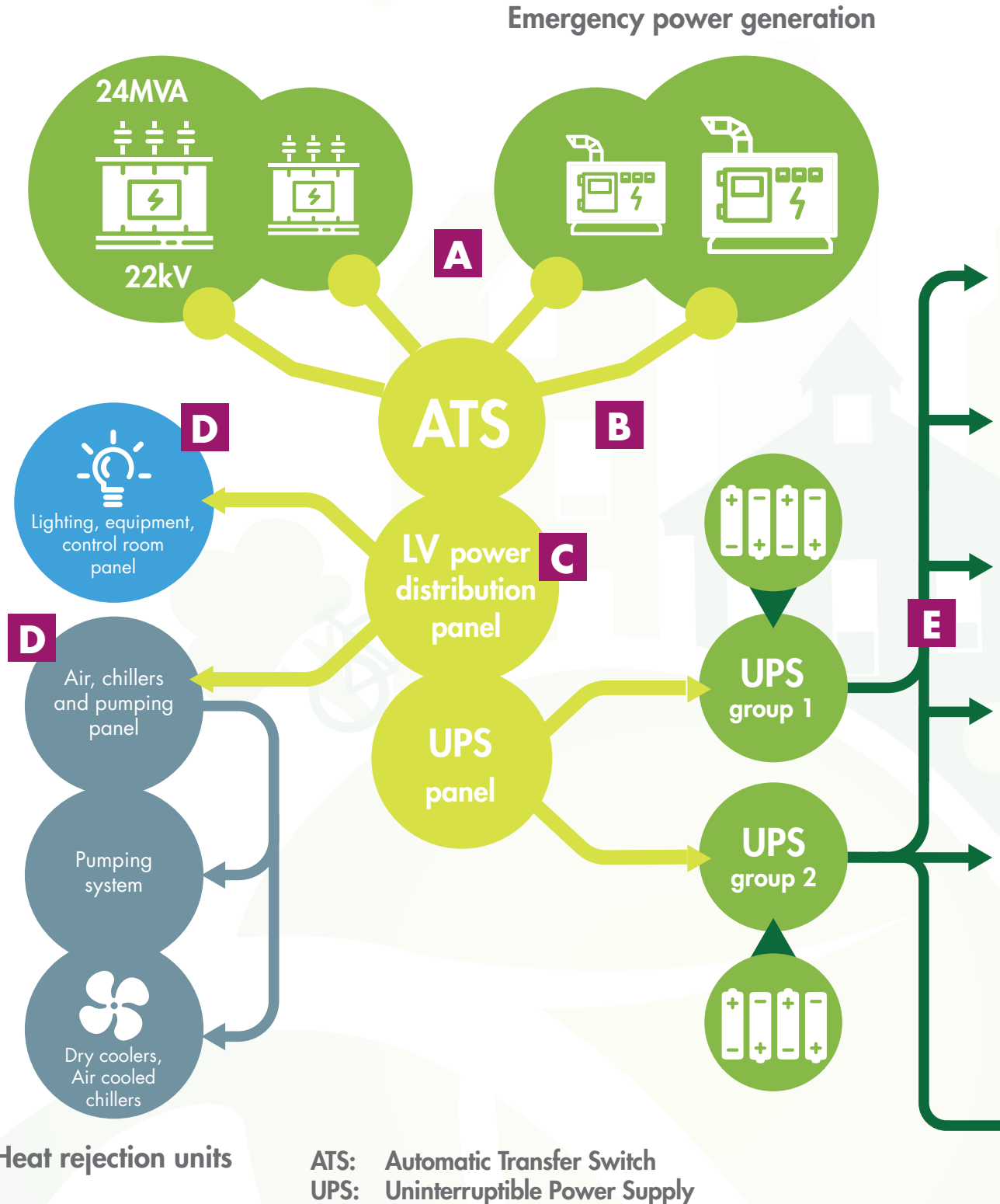

Servers room

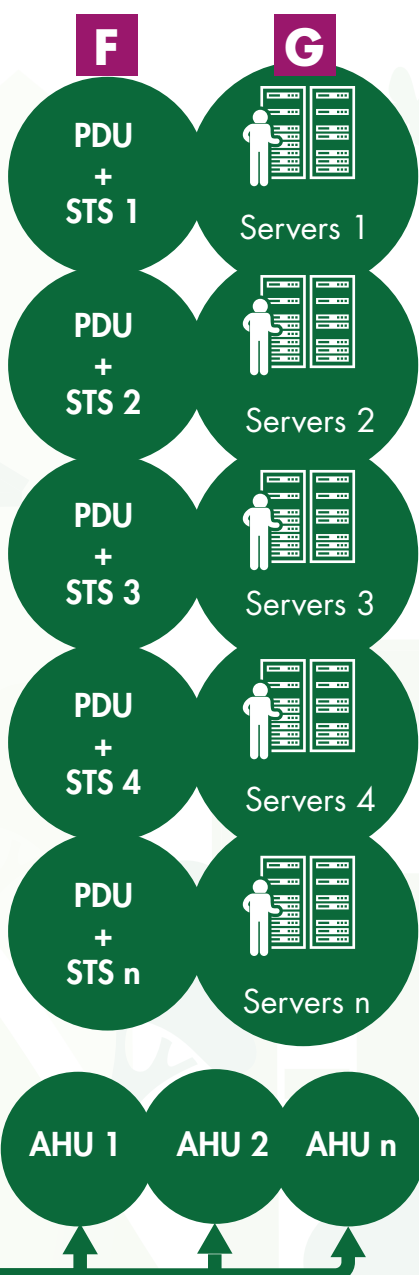

PDU: Power Distribution Unit
 STS: Static Transfer Switch
 AHU: Air Handling Unit

The topics

	Page
A Utility, main, submetering and retrofit solutions	8
B Data management platform	6-7
C Main metering with harmonics analysis	10-11
D Quick-fit solutions for main and sub-metering	12-13
E Protection devices	9
F PDU-based monitoring	16-17
G Power busbar based monitoring	14-15

Platform

One platform, many integration solutions

Communication, analysis and reporting in one unit

UWP 3.0 SE is a core unit capable to collect data from meters and other sensing devices suitable to be used to monitor critical loads.

UWP 3.0 SE is key to meet today's Energy Managers and Energy Service Companies requirements to achieve energy efficiency goals, but also to monitor the behaviour of critical loads such as dry coolers, air cooled chillers and servers in Data Centers. It can provide, as a first step, all the remote, on-premise, or cloud functionalities. Simple architecture, short commissioning time, cost reductions, error proof configuration, expandability and scalability are the distinctive characteristics of this unit. UWP 3.0 SE is a Web-Server but also a gateway. UWP 3.0 SE is Microsoft® certified for IoT. One or many UWP 3.0 SE pushing their data to the Microsoft® Azure IoT Hub will allow System Integrators to extend the level of integration to other systems. Data can be shared locally via Modbus/TCP or BACnet, while M2M makes integration with other systems possible via Rest-API or standard FTP, SFTP, FTPS communication. Excel® reports can be generated online or via the embedded scheduler.

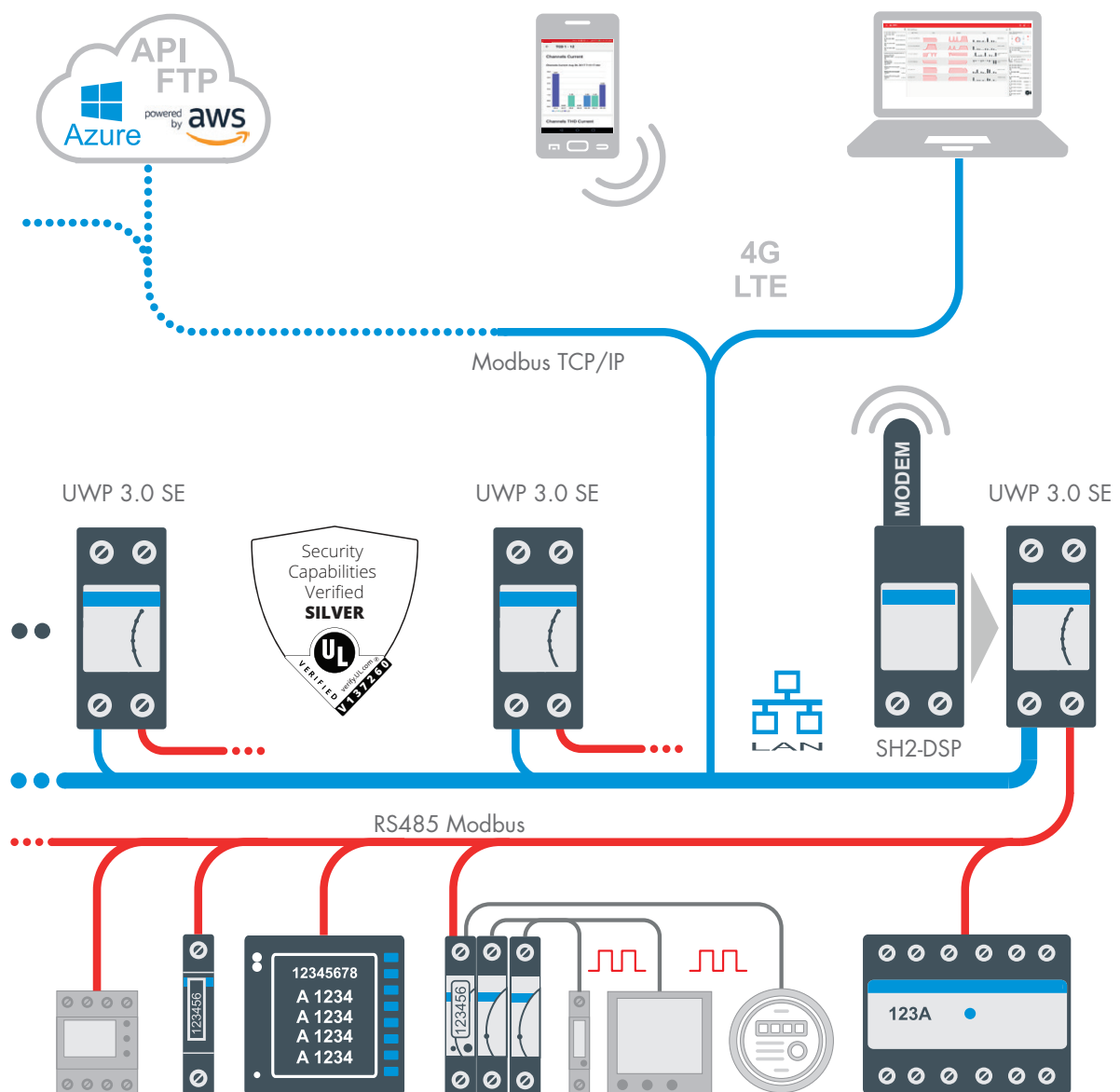

Tools to properly display the key variables

The UWP 3.0 SE unit allows you to automate the process of collecting data points from multiple meters and other sensing units.

The embedded Web-Server allows both system integrators and Energy Managers, by means of Dashboards, to mix both history and real time data. This means, to display the key plant variables using analysis tools such as tables, trends, histograms, pies, comparison functions, which can be used also to perform diagnostics on both communication and data during plant commissioning, particularly when UWP 3.0 SE is part of a complex management architecture.

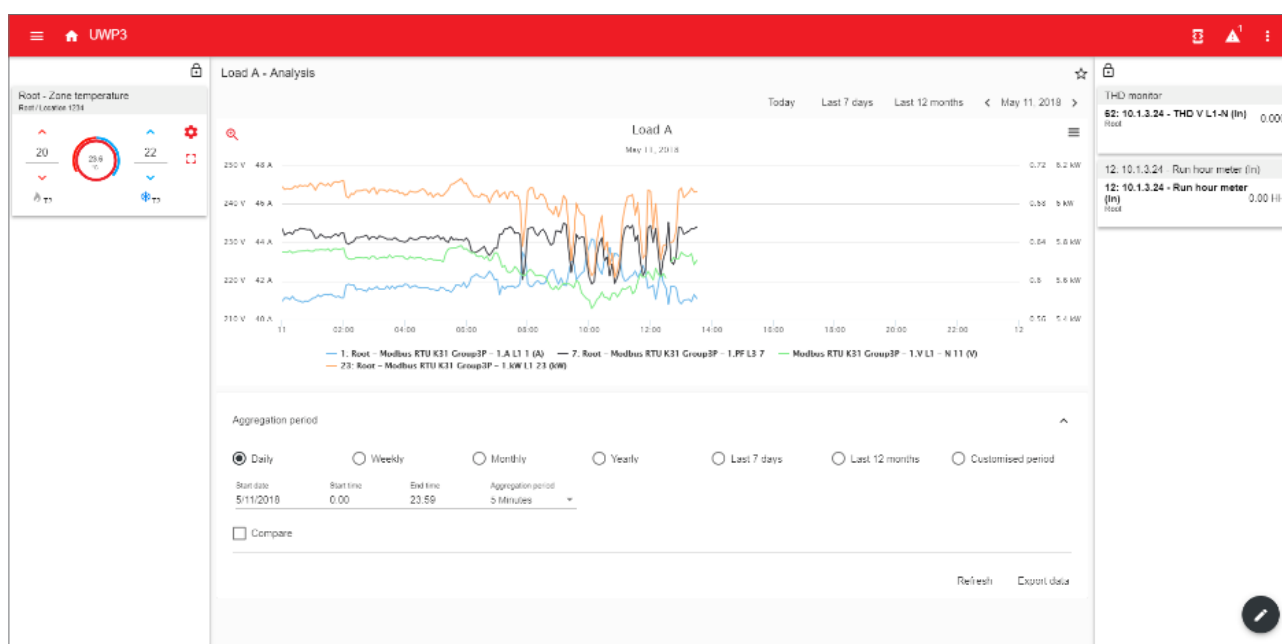

UWP 3.0 SE

- Micro PC with embedded Web Server, WEB services and data logger functions
- Ethernet Modbus TCP master/slave function
- 2 x RS485 ports, both of which support up to 64 Modbus devices
- Data display (charts and tables)
- Real time or scheduled data export to Excel, CSV and HTML formats
- 4GB internal memory, Back-up memory on micro SDHC and USB
- Energy analysis of each load
- Configurable dashboards with data analytics and real time display functions
- Embedded Modbus editor for compatibility with any Modbus meter
- Alarm management (e-mail or SMS by means of SH2-DSP)
- 2-DIN module housing
- 12 – 28 V dc power supply



SH2-DSP

- Modem extension unit for UWP 3.0 SE
- 3G or 4G Mobile Internet connectivity with SMS alerts and SMS commands management
- 2-DIN module housing
- 20 – 28 V dc power supply



Monitoring

Different needs, different solutions

Existing main and sub metering

Already installed pulse output-based meters can still be part of a data collection system!

In many installations, old fashioned meters are still working properly but energy information is still collected manually with both high data collection costs and potential transcription errors. Now, concentrating on multiple meters' pulse outputs and making them available as RS485 Modbus counters is possible, thanks to the modular VMU-MC + VMU-OC solution ranging from 2 to 11 pulse inputs (counters). Pulse to Modbus conversion is the key to automatic data collection, which ensures quality, granularity, and full management of data.

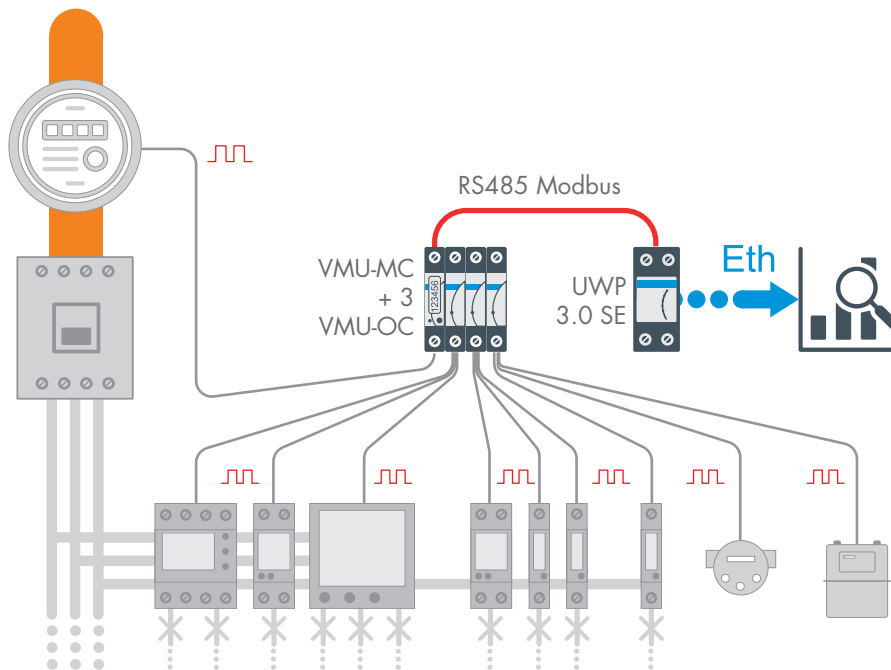

VMU-MC, VMU-OC

- 1-DIN module housing
- Modular
- RS485 communication port
- 11 total inputs available
- Unit of measure: kWh, kvarh, kVAh, kJ, kcal, ft³, h, pcs, lbs

VMU-MC:

- LCD display for: status, counter, any active tariff
- 2 inputs available (for pulses counting or for up to 4 tariffs selection)
- 15 – 24 V dc power supply

VMU-OC:

- 3 inputs available (for pulses counting only)

■ The UCS software configuration advantages extended also to VMU-MC and VMU-OC!

UCS features for configuring devices, storing configurations into a database, sharing configurations and logs among users, and checking the device status are available also for VMU-MC/OC. Therefore the two VMU-MC inputs can be set as counters, or one as a counter and one to sense tariff change as a digital input, managing automatically the energy increase for both tariff 1 and tariff 2. Every counter input and function has an independently configurable pulse weight.

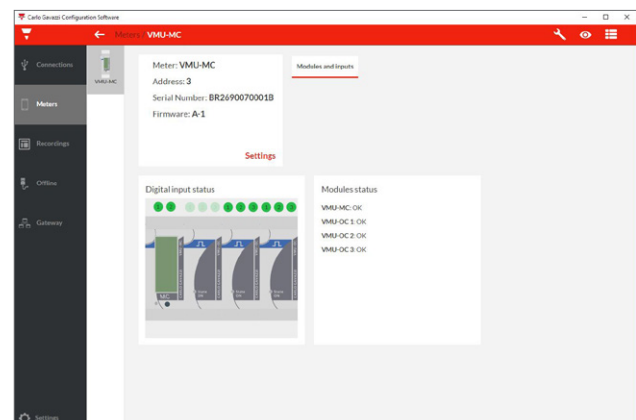

MRCD type Installation Protection Devices

Avoid a nuisance trip of protection and maintain the availability of power supply.

How to prevent injury? In the wide range of protection devices, there is a family of units called RCD Residual Current Device. The purpose of an RCD is to prevent threats to life by protecting against the risks of electrocution and fire caused by earth faults.

How to detect dangerous earth leakage currents? In industrial, commercial and data center applications, due to their specific requirements, the device used is called an MRCD Modular Residual Current Device. More specifically, it is an earth leakage current relay which can detect by means of an external core balance transformer the earth leakage current.

How to avoid power supply interruption? Both RCDs and MRCDs are prone to nuisance trips from normal harmless earth leakage. Those are due to external factors, such as a high current discharge due to lightning or to an earth rod placed close to a neighbouring earth rod on a building. A nuisance trip would affect the availability of power supply, which for example in a production facility, or in a data center because of its nature, is not allowed.

The Carlo Gavazzi solution is made of two models: DEA71 and DEB71, combined with CTG, our core balance transformer family. Our MRCDs comply with IEC/EN 60947-2, so to avoid nuisance trips and fulfil the "A" type operating characteristic so to work in case either of presence or absence of dc component of residual currents.

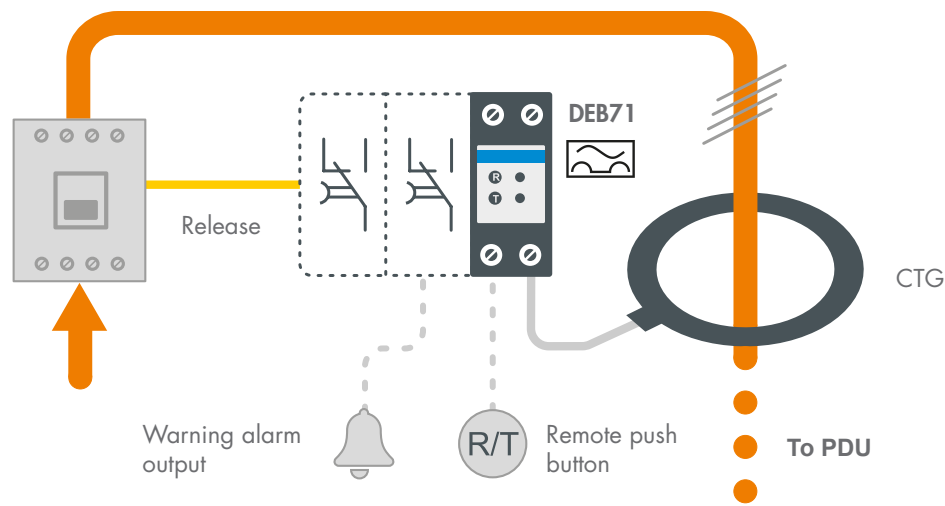

- DEA71**
- Fixed current setting: 30 mA or 300 mA
 - 2 relay outputs for warning and alarm
 - Input for remote Reset / Test
 - 24 – 240 V ac power supply

- DEB71**
- Adjustable setting from 30 mA to 5 A
 - Adjustable delay up to 5 s
 - Leakage level LED bar
 - 2 relay outputs for warning and alarm
 - Input for remote Reset / Test
 - 24 – 240 V ac power supply

- CTG, core balance transformer**
- Easy installation
 - High accuracy and sensitivity

Model	Hole size
CTG35	1.38 in (35 mm)
CTG50	1.97 in (50 mm)
CTG70	2.75 in (70 mm)
CTG120	4.72 in (120 mm)
CTG160	6.3 in (160 mm)
CTG210	8.27 in (210 mm)

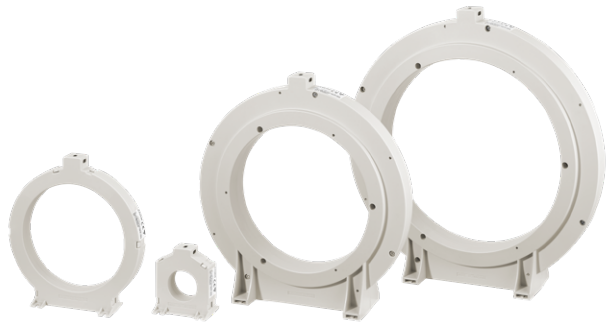

Monitoring

Harmonics and other analysis

Main metering with module-based expandable functions

A high-spec meter is often time demanding due to its installation and commissioning complexity: how can you make it time and cost effective?

Yes, by selecting the most appropriate device to meet the different installation and application needs among the three available power analyser models. Metering capabilities, and control functions, as well as a common modular system are the key features. Panel Builders, System Integrators and Installers enhance and speed up their activities of initial meter configuration, communication diagnostics and commissioning with the help of the combination of new and innovative tools like OptoProg, UCS desktop, and UCS mobile.

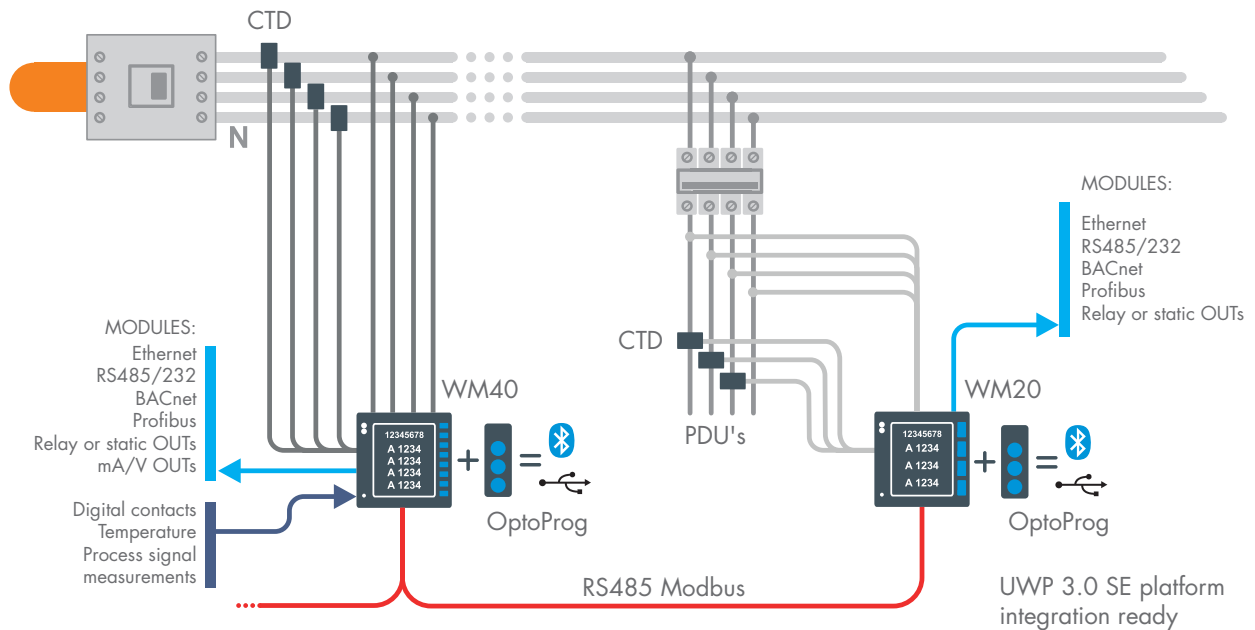

WM20

- 3.78*3.78 in (96*96 mm) panel mounting housing with front protection degree NEMA4X/12 (IP65)
- 5 A current inputs for current transformers
 - Up to 793 V L-L measuring inputs
 - Basic accuracy (V/A): $\pm 0.2\%$ RDG
- Single and three-phase measurements: V, A, An, Hz, PF, W, VA, var, run-hour, kvarh, bi-directional kWh (cl. 0.5s IEC62053-22)
 - 9+1-DGT counter variables, backlit LCD display
 - Modular housing (see the modules list besides)
 - Optical port for fast data reading and configuration
- Universal power supply (90 - 264 V ac/dc, 21 - 55 V ac/dc)
- THD analysis up to 31st harmonics with source detection, single harmonics via Modbus
- 3*4 DGT instantaneous variables, LCD display
- Max values of all power variables
- Automatic scrolling pages
- 2 freely configurable virtual alarms

WM30

- 5 A current inputs for current transformers
 - Up to 793 V L-L measuring inputs
 - Basic accuracy (V/A): $\pm 0.2\%$ RDG
- 9+1-DGT counter variables, backlit LCD display
- Modular housing (see the modules list besides)
- Optical port for fast data reading and configuration
- Universal power supply (90 - 264 V ac/dc, 21 - 55 V ac/dc)
- THD analysis up to 31st harmonics with source detection, single harmonics via Modbus
- 4*4 DGT instantaneous variables, LCD display
- Avg and max values of all system and single phase variables
- 4 freely configurable virtual alarms
- Real time clock
- Other features, same as WM20

WM40

- 4-tariff management
- Factor K and TDD metering
- 16-alarm PLC logic and digital inputs for utility metering, built-in event and data stamping for instantaneous variables and load profiling
- Other features, same as WM30

Modules

WM20/WM30/WM40

- RS485/RS232 Modbus RTU
- BACnet IP
- BACnet MS/TP
- Ethernet (Modbus TCP)
- EtherNet/IP (WM20 excluded)
- Profibus DP-VO
- 2-static and relay outputs

WM30

- 2*20 mA dc or 2*10 V dc outputs

WM40

- Up to 4*20 mA dc or 10 V dc outputs
- 6-channel digital inputs, up to 6 relay/8 static outputs + OR/AND alarm logic management
- Direct An + Temperature + Process signal measurements



Advanced configuration and commissioning tools

An innovative solution to drastically reduce both configuration and commissioning time!

The installation, the configuration, and the commissioning of a power analyser has an intrinsic complexity which is due not only to the product itself, but also to the sequence of events which usually starts in the workshop of a Panel Builder and moves to the plant for the final installation. Hence, one product, which for different reasons and in different contexts moves through different professionals. To be able to be effective, there is the need to be able to supply a tool matching the skills and needs of different people. OptoProg, with its App, or simply as desktop software, is the best answer to simplify the whole process.

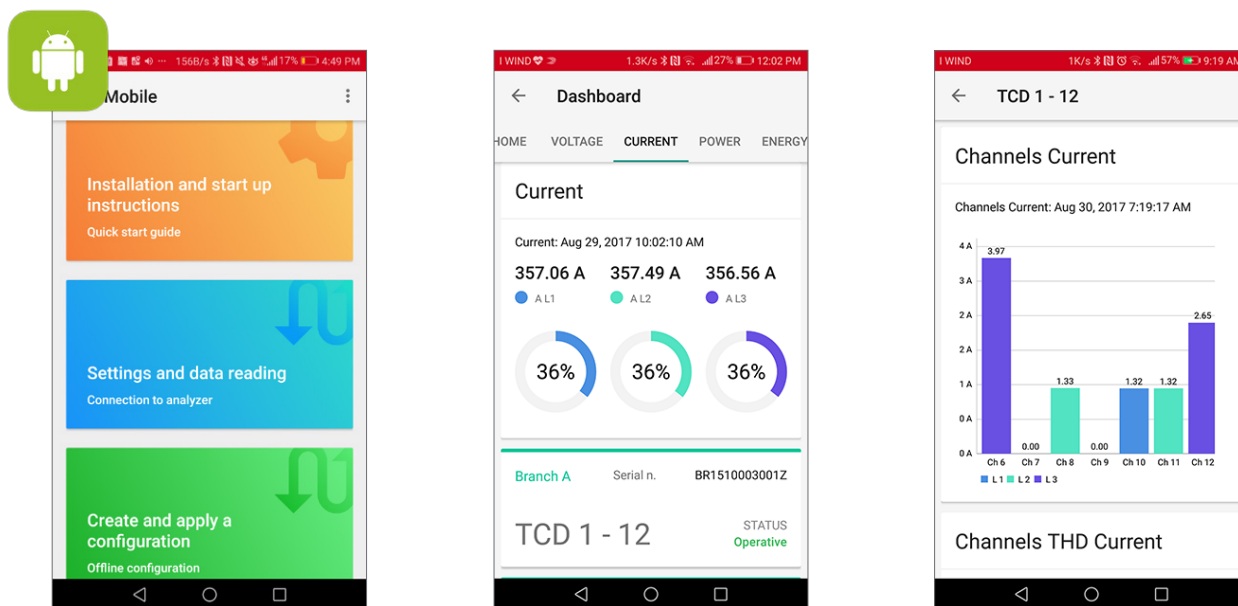

How do you do it? OptoProg + UCS is the solution!

OptoProg, the optical port-based coupling unit with built-in rechargeable battery, provided with both USB and Bluetooth communication capabilities to be used in combination with either UCS desktop or UCS Mobile (Android), with its excellent usability, allows the Panel Builder to set all initial metering parameters without physically using the meter front keypad.

If the panel is produced in series with the same overall characteristics and meter settings, by using the configuration upload and download function, the process is further shortened and error free. Once the distribution board with the power analyser is on site, the System Integrator using its OptoProg unit and UCS software can download the meter configuration parameters, change them, add alarms and upload the new configuration to the power analyser again to complete the process. With the same UCS it is possible to test the communication to other devices in the same Modbus network. The whole OptoProg process can be performed without opening the distribution board door, making this process more efficient, effective and safe. Once everything is done, just remove OptoProg from the power analyser and install it on another meter.

OptoProg

- Bridge mode use with embedded optical port
- Built-in lithium battery for one month operations
- Sleep mode for energy savings
- Configuration and communication status LED
- Bluetooth 2.0, 2.1, 3.0 and 4.0 connectivity

- Micro-USB B port
- FCC and IC approvals



OptoProg is compatible with: WM15, WM20, WM30, WM40, WM50.

Monitoring

Server and regular loads monitoring

How to cut costs with the quick-fit solution in production facilities

In most cases these are retrofit installations. The use of a proper monitoring system will manage a combination of regular loads and servers.

“Quick-fit” means: installation flexibility and TCO reduction, performed using a detachable display which allows the unit to be mounted on either a DIN-rail or on a panel; quick connections of the current sensors and the replacement of two regular 3-phase meters or six single-phase meters with one compact unit only EM271.

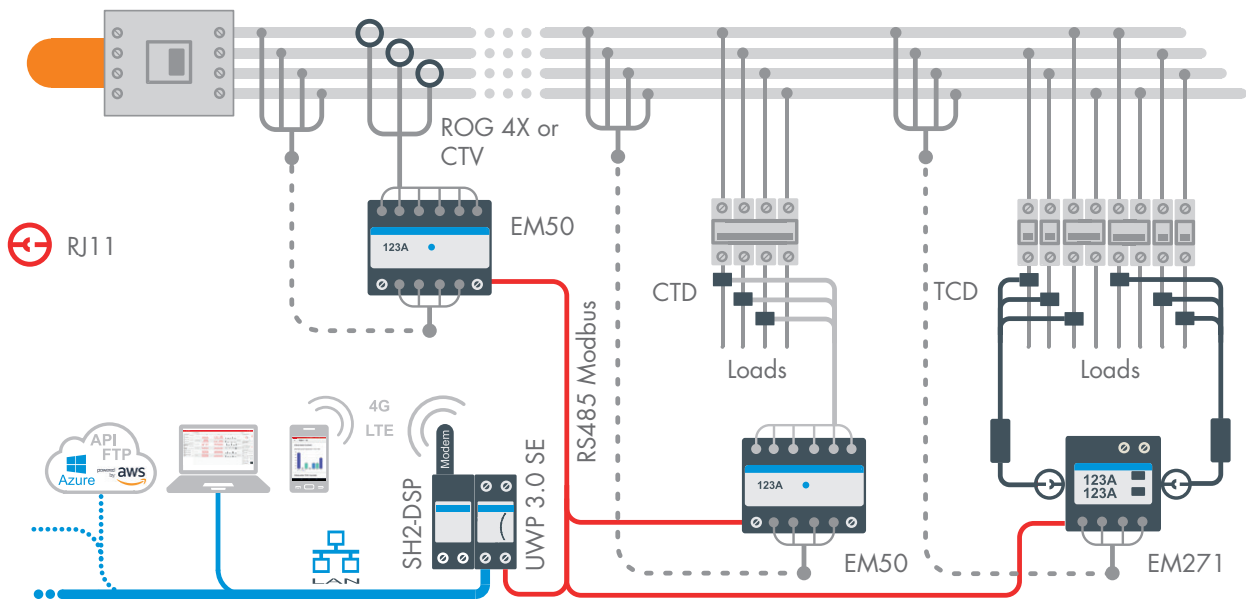

EM50, main and sub metering solution

- 6-DIN modules housing, 7-DGT backlit LCD display
- CT 5 A current inputs. 333 mV, Rogowski coil and 80 mA inputs for current sensors
- 100 – 600 V L-L measuring inputs
- On display: sys. and ph. +kWh, run hour meter; sys. and ph.: V L-N, A, An, W, Hz, °F
- Over bus (in addition to "on display"): tot. and tariff ±kWh/kvarh; sys. and ph. ±kVAh; 4 quadrant tot. and tariff kvarh; sys. and ph.: V L-L, var, VA, PF; demand and max. dmd: A, W, var, VA
- RS485 Modbus RTU
- 100 – 415 V ac auxiliary power supply
- Basic accuracy ±0.25% RDG (V/A), class 0.5 (kWh) according to ANSI C12-20
- More information available on page 18

CTV and ROG 4X series, sensing solutions

- **CTV 1X-2X-3X-4X-6X-8X.** Split-core current sensing unit, 333 mV output.

Model	Primary (A)	Hole size
CTV 1X and CTV 2X	60 and 100	0.38 and 0.61 in (9.6 and 15.5 mm)
CTV 3X, CTV 4X and CTV 6X	200 and 400	0.61, 0.8 and 1.41 (15.5, 20.5 and 36 mm)
CTV 8X	800	2*3.53 in (50*89.8 mm)

- **ROG 4X.** Rogowski coil current sensors. Primary: 20 to 4000 A, diameters: 3.54, 4.72, 7.87, 11.4 in (90, 120, 200, 290 mm)

EM271, sub metering solution

- Patented meter, 4-DIN and 2.83*2.83 in (72*72 mm) solution in the same housing for DIN-rail or panel mounting. Detachable 3*3-DGT/7-DGT display
- 208 V L-L ac and TCD-based current measuring inputs
- Current measurement by two basic TCD units with quick RJ11 plugs (see TCD M series)
- Quick configuration by automatic recognition of TCD units
- 2*3-phase energy analysers with sum function in the same unit
- Measurements: V, A, Hz, PF, W, VA, var, bi-directional kWh
- RS485 Modbus RTU. 2 pulse outputs (loads 1 and 2)
- Self powered (120 V ac)
- Basic accuracy (kW): ±2.0 % RDG (meter + TCD M unit), kWh: class 1 (IEC62053-21)

TCD 0M-1M-2M-3M, MM sensing solutions

- Combination of three single split-core current sensing units

Model	Primary (A)	Hole size
TCD 0M and TCD 1M	60 and 100	0.38 and 0.61 in (9.6 and 15.5 mm)
TCD 2M and TCD 3M	200 and 400	0.61 and 0.80 in (15.5 and 20.5 mm)
TCD MM	Up to 10000(*)	See CTV series

- Basic TCD M unit (connected to three current sensors) for panel and DIN-rail mounting (*) Compatible with current sensors with 333mV output



How to cut costs with the quick-fit solution in banks

In most cases these are installations with limited space to fit a proper monitoring system.

Here again, we have all the benefits provided by the Carlo Gavazzi "Quick-fit" solution, but using in this case either 3-channel or 6-channel compact sensing units, in three-phase or one-phase circuits. This means, referring to the drawing below, also a reduction of 65% of all connections vs a regular solution but also using, in comparison, less devices.

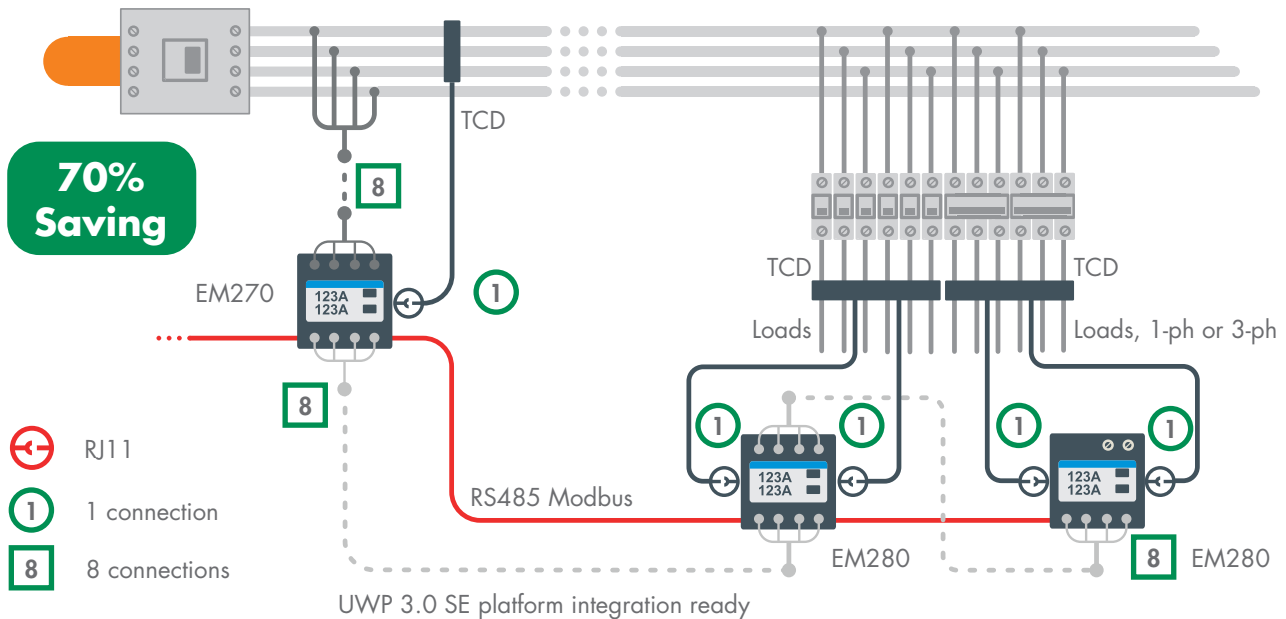

EM270 MV6, main metering solution

- Patented meter, 4-DIN and 2.83*2.83 in (72*72 mm) solution in the same housing for DIN-rail or panel mounting. Detachable 3*3-DGT/7-DGT display
- 208 V L-L ac and TCD-based current measuring inputs
- Current measurement by two triple solid-core sensing units with quick RJ11 plugs (see TCD X series)
- Quick configuration by automatic recognition of TCD units
- 2*3-phase energy analysers with sum function in the same unit
- Measurements: V, A, Hz, PF, W, VA, var, bi-directional kWh
- Basic accuracy (kW): $\pm 1.25\%$ RDG (meter + TCD x unit). kWh: class 1 (IEC62053-21)
- RS485 Modbus RTU. 2 pulse outputs (loads 1 and 2)
- Self powered (120 V ac)

TCD 1X-2X-3X, sensing solutions

- Triple solid-core current sensing unit

Model	Primary (A)	Bus-bar sizes	Center-to-center distance
TCD 1X	3*160	6.10*0.98 in (15.5*25mm)	0.98 in (25mm)
TCD 2X	3*250	0.83*0.98 in (21*25mm)	1.38 in (35mm)
TCD 3X	3*630	1.22*1.22 in (31*31mm)	1.77 in (45mm)

EM280 MV6, sub metering solution

- Patented meter, 4-DIN and 2.83*2.83 in (72*72 mm) solution in the same housing for DIN-rail or panel mounting. Detachable 3*3-DGT/7-DGT display
- 208 V L-L ac and TCD-based current measuring inputs
- Current measurement by one 6-channel solid-core sensing unit with quick RJ11 plugs (see TCD 06 series)
- Quick configuration by automatic recognition of TCD units
- 2*3-phase/6*1-phase energy analysers with sum function in the same unit
- Measurements: V, A, Hz, PF, W, VA, var, kWh
- Basic accuracy (kW): $\pm 1.25\%$ RDG (meter + TCD-06 unit). kWh: class 1 (IEC62053-21)
- RS485 Modbus RTU. 2 pulse outputs (loads 1 and 2)
- Self powered (120 V ac)

TCD 06BX-06BS, sensing solutions

New installation, TCD 06BX	Retrofitting, TCD 06BS
6-channel solid-core current sensing unit	6-channel split-core current sensing unit
• Primary: 6*32 A, hole size: 0.27 in (7 mm). Center-to-center distance: 0.69 in (17.5 mm). RJ11 cable length: 31.5, 59.05 or 78.74 in (80, 150 or 200 cm)	



Up to 630A

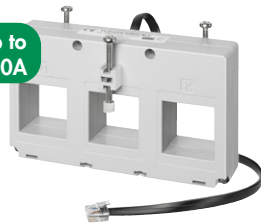

32A

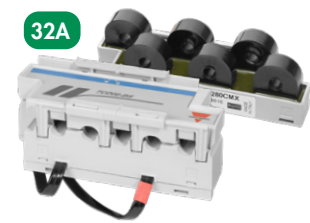

Monitoring

Power busbar-based monitoring in Data Centers

A 94% commissioning time saving

For both existing and new installations based on power bus-bar trunking systems (bus-duct).

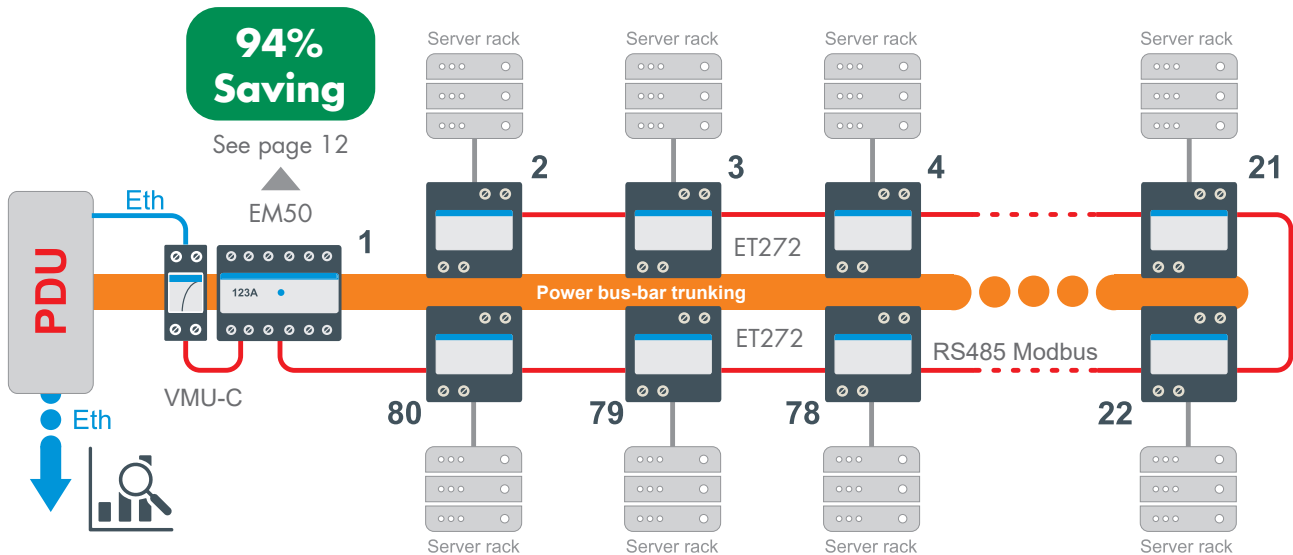

ET272, main and sub metering solution for tap-off boxes

- Patented meter, 4-DIN modules for DIN-rail mounting
- Up to 415 V L-L ac and TCD-based current measuring inputs
- Current measurement by two basic TCD units with quick RJ11 plugs (see TCD xM series)
- Quick configuration by automatic recognition of TCD units
- Self addressing in a Modbus system (in combination with VMU-C)
- 2*3-phase energy analysers with sum function in the same unit
- Measurements: V, A, Hz, PF, W, VA, var, bi-directional kWh
- Basic accuracy (kWh): $\pm 2.0\%$ RDG (meter + TCD xM unit). kWh: class 1 (IEC62053-21)
- Data format: 3-DGT (instantaneous variables)/7-DGT (totalizers)
- RS485 Modbus RTU. 2 pulse outputs (loads 1 and 2)
- Self powered (120 V ac)

TCD 0M-1M-2M-3M-MM, sensing solutions

- Triple split-core sensing unit for panel and DIN-rail mounting

Model	Primary (A)	Hole size
TCD 0M	60	0.38 in (9.6 mm)
TCD 1M	100	0.61 in (15.5 mm)
TCD 2M	200	0.61 in (15.5 mm)
TCD 3M	400	0.80 in (20.5 mm)
TCD MM	Up to 10000(*)	-

(*) using CTV sensing units, see page 12.

VMU-C gateway and web-server solution

- VMU-C EM and ET272 are mandatory parts of the bus-duct solution
- 2-DIN module housing. 12 – 28 V dc power supply
- Micro PC with embedded Web Server, WEB services and data logger functions
- Ethernet Modbus TCP master/slave function
- One RS485-Modbus port for the management of up to 80 ET272
- Data display (charts and tables). Real time or scheduled data export to Excel, CSV and HTML formats
- 4GB internal memory, Back-up memory on micro SDHC and USB
- Energy analysis of each load. Costs analysis
- Virtual meter with sum function
- Alarm management (e-mail or SMS by means of SH2-DSP)

SH2-DSP

- Modem extension unit for VMU-C
- 3G or 4G Mobile Internet connectivity with SMS alerts and SMS commands management
- 2-DIN module housing
- 20 - 28 Vdc power supply

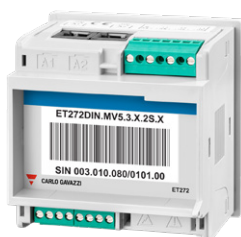

Up to 10kA



The saving details

How ET272 + VMU-C achieve the commissioning time saving goal.

Traditional tap-off box solution: the first configuration, the following addressing and the final commissioning in case of 16 bus-bar trunking systems of 32 tap-off boxes each (total more than 2 hours) require a total of about 34 hours of Professionals work.

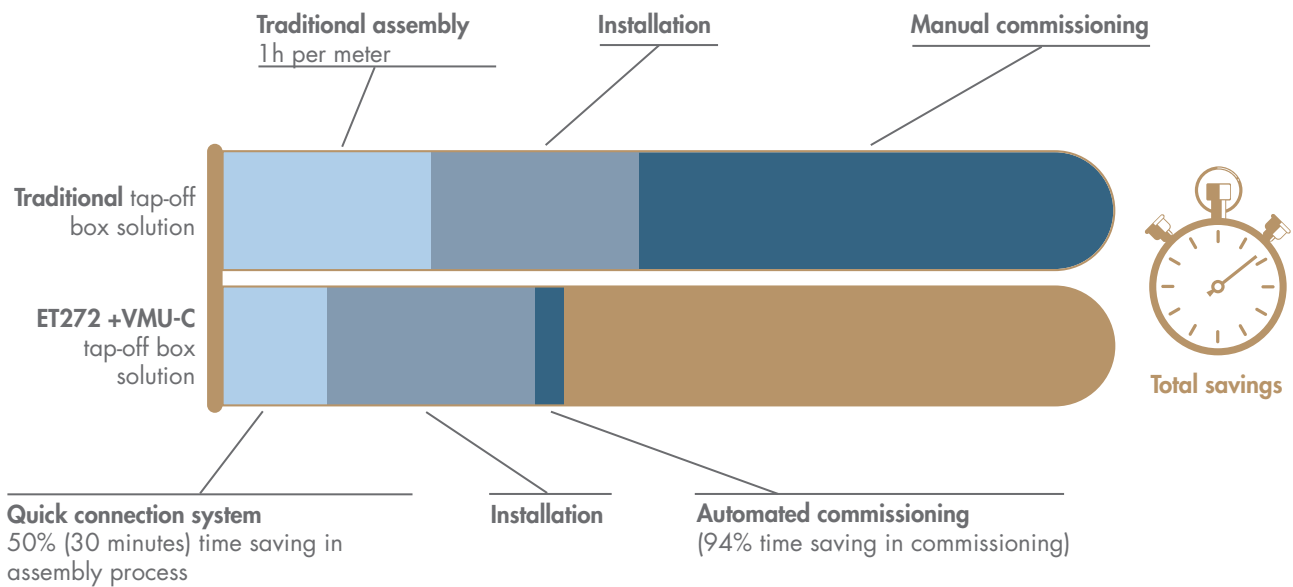

ET272 + VMU-C tap-off box solution: no manual configuration, no ID addressing, a general process improvement. Leading to a total configuration and commissioning time reduction from 34 hours of Professionals work to only 2 hours!

Step	Actor	Site	Action	Benefit
1	Panel builder	Production	Quick tap-off box assembly and ID label sticking on the tap-off box.	Quick connections and the split-core current sensors of ET272 (see next page).
2	Installer	Data center	Affixing the ID labels to the installation document, and tap-off box installation on the bus-bar.	Easy identification of the tap-off box in order to minimize positioning errors.
3	System integrator	Data center	ID labels installation document barcode reading.	Full automated commissioning thanks to the Embedded VMU-C tools.

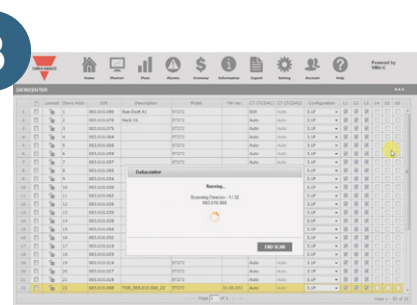

Monitoring

PDU-based monitoring in Data Centers

A 75% installation time saving

In a single solution the combination of a three-phase main meter with CT inputs and 65A integrated TCD sub-meter units with up to 96 single-phase channels or 32 three-phase channels.

When the electrical system is different from a bus-bar trunking or bus-duct system, and numerous loads are fed from a common distribution board, than WM50-96 is the ideal solution for branch circuit monitoring. The solution is based on one core unit WM50, which is usually installed and connected on the mains, and some TCD12 units as combined meters installed downstream the MCBs for single phase or three-phase loads. As the whole installation cost derives not only from the cost of the components, but even more by installation savings and commissioning costs, this innovative solution allows you to achieve more than 75% installation and commissioning savings vs. standard solutions.

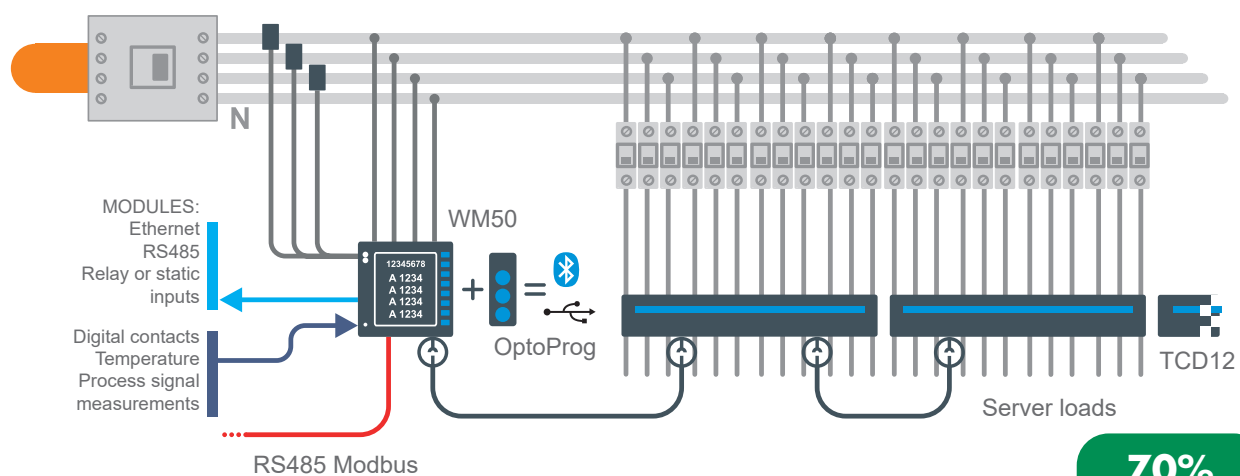

70% Saving

WM50, main metering solution for distribution boards

- 3.8*3.8 in (96*96 mm) panel mounting meter with (IP65) front protection degree and modular housing
- Up to 480 V L-L ac and 5 A CT measuring inputs
- Single and three-phase measurements: V, A, An, Hz, PF, W, VA, var, run-hour, kvarh, bi-directional kWh (cl. 0.5S IEC62053-22), THD analysis up to 31st harmonics, single harmonics via Modbus
- Basic accuracy (V/A): $\pm 0.2\%$ RDG
- 9+1-DGT totalized and 4-DGT instantaneous variables LCD display
- Optical port for fast data reading and configuration
- Universal power supply (90 – 260 V ac/dc)
- 4-tariff management
- 16-alarm PLC logic and digital inputs for utility metering, built-in event and data stamping for instantaneous variables

WM50, I/O optional modules

- RS232/RS485
- Ethernet (Modbus TCP)
- 6-channel digital inputs, up to 4-relay/6-static outputs + OR/AND alarm logic management
- Direct An + Temperature + Process signal measurements



◀ OptoProg removable unit in combination with UCS software or App eases and speeds up the meter configuration (see page 17).

From main metering to submetering

WM50 is the combination in a single solution of a three-phase main meter with CT inputs and 65A integrated TCD submeter units up to 96 channels.



- TCD12, sub metering**
 - Primary: 12*65A
 - Hole size (mm): 8.5
 - Center-to-center distance (mm): 17.5mm
- RJ cable length (cm): 30 to 500
 - 12-channel split-core current sensing unit
 - Accuracy Class 2 (kWh) according to EN62053-21 (meter + TCD unit)
- Up to 96 channels: kWh, W, var, VA, PF, A, THD A
 - Data available via communication module on board of WM50

The tools to speed up the configuration and commissioning time

From laptop to smartphone!

- OptoProg (1): the optical port coupling unit with rechargeable battery, provided with both USB and Bluetooth communication capabilities to be used in combination with UCS.
- UCS desktop: the laptop configuration and diagnostics platform (2) compatible with all Carlo Gavazzi meters.
- UCS Mobile: the configuration and diagnostics App (3) for Android smart phones.

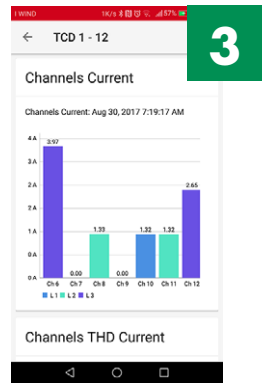
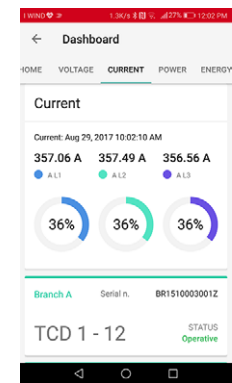
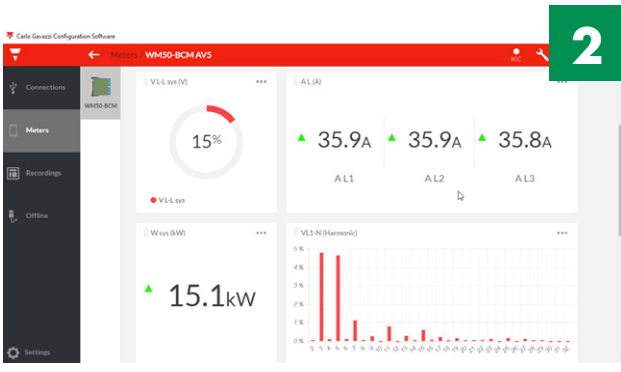

Monitoring

Current adapters and quick-fit solutions

Solid-core current adapters

From compact sizes to high currents and from solid-core to split-core, these are the current adapters for Carlo Gavazzi meters and the appropriate solution for any kind of installation.

CTD 1/2/3/4-X

CTD	from (A)	to (A)
1x	50	300
2x	40	600
3x	50	800
4x	150	1600

- Solid core for cable or bus-bar
- Cable diameter: 0.90 to 2 in (23 to 51 mm)
- Bus-Bar: 0.79*0.20 in to 2.5*0.79 in or 2*1.69 in (20*5 mm to 64*20 mm or 51*43 mm)
- Secondary: 5 A (standard), 1 A (available upon request)
- Sealable terminal covers
- IEC61869-2 compliant

CTD 8/9/10-V-H

CTD	from (A)	to (A)
8 V/H	150	1600
9 V/H	400	2000
10 V/H		

- Solid core for cable or bus-bar
- Bus-Bar: 1.22*3.19 in to 2*4.96 in (31*81 mm to 51*126 mm)
- Secondary: 5 A (standard), 1 A (available upon request)
- Sealable terminal covers
- IEC61869-2 compliant

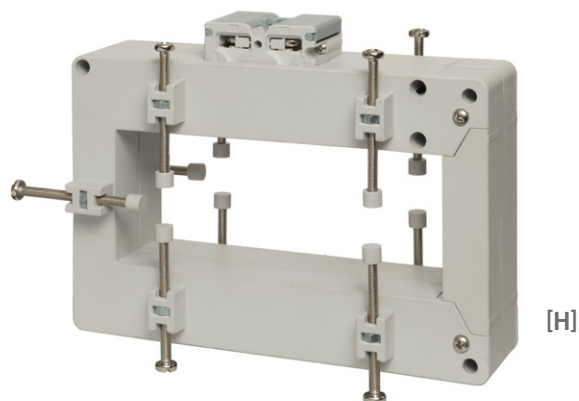
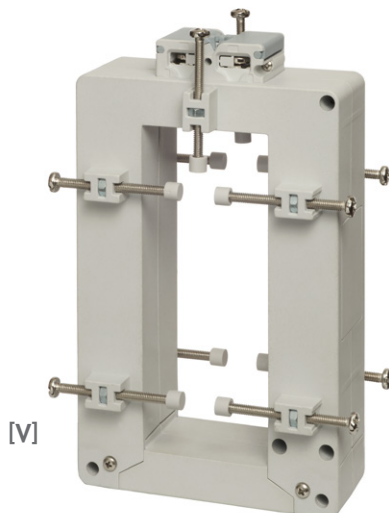
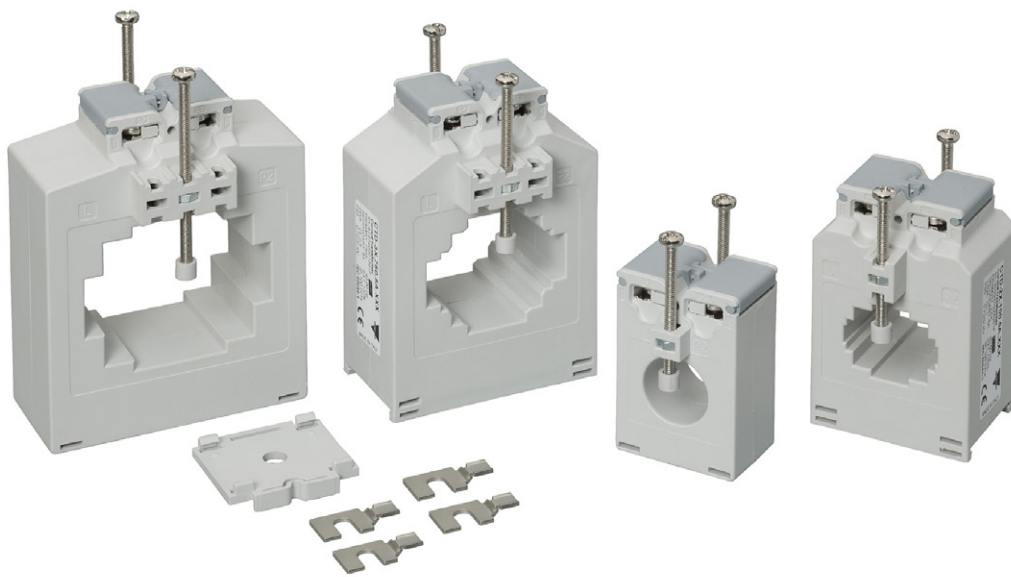

Split-core current adapters

CTD 5/6-S

CTD	from (A)	to (A)
5 S	100	400
6 S	150	1000

- Split-core for cable or bus-bar
- Bus-Bar: 1.02*1.25 in, 1.97*1.26 in (26*32 mm, 50*52 mm)
- Secondary: 5A (standard), 1 A (available upon request)
- Sealable terminal covers
- IEC61869-2 compliant

CTD 8/9/10-S

CTD	from (A)	to (A)
8 S	150	1600
9 S	400	2000
10 S		

- Split-core for cable or bus-bar
- Bus-Bar: 1.22*3.19 in to 1.97*4.92 in (31*81 mm to 50*125 mm)
- Secondary: 5 A (standard), 1 A (available upon request)
- Sealable terminal covers
- IEC61869-2 compliant

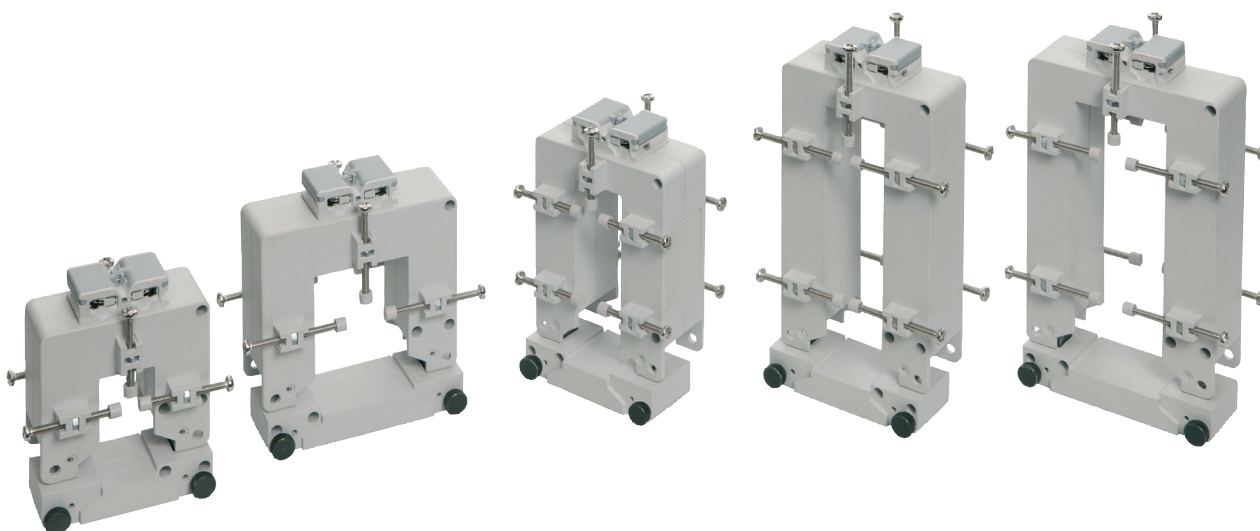

CTA 5/6

CTA	from (A)	to (A)
5 X	100	300
6 X	200	600

- Split-core for cable
- Secondary: 5 A
- Cable diameter: 0.94 in (24 mm) (5X), 1.42 in (36 mm) (6X)
- IEC61869-2 compliant



OUR SALES NETWORK IN EUROPE

AUSTRIA

Carlo Gavazzi GmbH
Ketzerergasse 374,
A-1230 Wien
Tel: +43 1 888 4112
Fax: +43 1 889 1053
office@carlogavazzi.at

BELGIUM

Carlo Gavazzi NV/SA
Mechelsesteenweg 311,
B-1800 Vilvoorde
Tel: +32 2 257 41 20
sales@carlogavazzi.be

DENMARK

Carlo Gavazzi Handel A/S
Over Hadstenvej 40,
DK-8370 Hadsten
Tel: +45 89 60 61 00
Fax: +45 86 98 15 30
handel@gavazzi.dk

FINLAND

Carlo Gavazzi OY AB
Ahventie, 4 B
FI-02170 Espoo
Tel: +358 9 756 2000
myynti@gavazzi.fi

FRANCE

Carlo Gavazzi Sarl
Zac de Paris Nord II, 69, rue de la Belle Etoile,
F-95956 Roissy CDG Cedex
Tel: +33 1 49 38 98 60
Fax: +33 1 48 63 27 43
french.team@carlogavazzi.fr

GERMANY

Carlo Gavazzi GmbH
Pfnorstr. 10-14
D-64293 Darmstadt
Tel: +49 6151 81 00 0
Fax: +49 6151 81 00 40
info@gavazzi.de

GREAT BRITAIN

Carlo Gavazzi UK Ltd
4.4 Frimley Business Park,
Frimley, Camberley, Surrey GU16 7SG
Tel: +44 1 276 854110
Fax: +44 1 276 682140
sales@carlogavazzi.co.uk

ITALY

Carlo Gavazzi SpA
Via Milano, 13,
I-20045 Lainate
Tel: +39 02 931 76 1
Fax: +39 02 931 76 301
info@gavazziacbu.it

NETHERLANDS

Carlo Gavazzi BV
Wijkermeerweg 23,
NL-1948 NT Beverwijk
Tel: +31 251 22 93 45
Fax: +31 251 22 60 55
info@carlogavazzi.nl

NORWAY

Carlo Gavazzi AS
Melkeveien 13,
N-3919 Porsgrunn
Tel: +47 35 93 08 00
Fax: +47 35 93 08 01
post@gavazzi.no

PORTUGAL

Carlo Gavazzi Lda
Rua dos Jerónimos 38-B,
P-1400-212 Lisboa
Tel: +351 21 361 70 60
Fax: +351 21 362 13 73
carlogavazzi@carlogavazzi.pt

SPAIN

Carlo Gavazzi SA
Avda. Iparraguirre, 80-82,
E-48940 Leioa (Bizkaia)
Tel: +34 94 480 40 37
Fax: +34 94 431 60 81
gavazzi@gavazzi.es

SWEDEN

Carlo Gavazzi AB
V:a Kyrkogatan 1,
S-652 24 Karlstad
Tel: +46 54 85 11 25
Fax: +46 54 85 11 77
info@carlogavazzi.se

SWITZERLAND

Carlo Gavazzi AG
Verkauf Schweiz/Vente Suisse
Sumpfstrasse 3,
CH-6312 Steinhausen
Tel: +41 41 747 45 35
Fax: +41 41 740 45 40
info@carlogavazzi.ch

OUR SALES NETWORK IN THE AMERICAS

USA

Carlo Gavazzi Inc.
750 Hastings Lane,
Buffalo Grove, IL 60089-6904, USA
Tel: +1 847 465 61 00
Fax: +1 847 465 73 73
sales@carlogavazzi.com

CANADA

Carlo Gavazzi Inc.
2660 Meadowvale Boulevard,
Mississauga, ON L5N 6M6, Canada
Tel: +1 905 542 0979
Fax: +1 905 542 2248
gavazzi@carlogavazzi.com

MEXICO

Carlo Gavazzi Mexico S.A. de C.V.
Circuito Puericultores 22, Ciudad Satelite
Naucalpan de Juárez, Edo Mex. CP 53100
Mexico
T +52 55 5373 7042
F +52 55 5373 7042
mexicosales@carlogavazzi.com

BRAZIL

Carlo Gavazzi Automação Ltda.
Av. Francisco Matarazzo, 1752
Conj 2108 05001-200 - São Paulo - SP
Tel: +55 11 3052 0832
Fax: +55 11 3057 1753
info@carlogavazzi.com.br

OUR SALES NETWORK IN ASIA AND PACIFIC

SINGAPORE

Carlo Gavazzi Automation Singapore Pte. Ltd.
61 Tai Seng Avenue #05-06
Print Media Hub @ Paya Lebar iPark
Singapore 534167
Tel: +65 67 466 990
Fax: +65 67 461 980
info@carlogavazzi.com.sg

MALAYSIA

Carlo Gavazzi Automation (M) SDN. BHD.
D12-06-G, Block D12,
Pusat Perdagangan Dana 1,
Jalan PJU 1A/46, 47301 - Petaling Jaya,
Selangor, Malaysia
Tel: +60 3 7842 7299
Fax: +60 3 7842 7399
info@gavazzi-asia.com

CHINA

Carlo Gavazzi Automation
(China) Co. Ltd.
Unit 2308, 23/F.,
News Building, Block 1, 1002
Middle Shennan Zhong Road, Futian District,
Shenzhen, China
Tel: +86 755 8369 9500
Fax: +86 755 8369 9300
sales@carlogavazzi.cn

HONG KONG

Carlo Gavazzi Automation
Hong Kong Ltd.
Unit No. 16 on 25th Floor, One Midtown,
No. 11 Hoi Shing Road, Tsuen Wan,
New Territories, Hong Kong
Tel: +852 26261332 / 26261333
Fax: +852 26261316

TAIWAN

Branch of Carlo Gavazzi Automation
Singapore Pte. Ltd.
22F-1, No.500 Shizheng Rd, Xitun Dist,
Taichung City 407,
Taiwan, China
Tel: +886 4 2258 4001
Fax: +886 4 2258 4002

OUR COMPETENCE CENTRES AND PRODUCTION SITES

DENMARK

Carlo Gavazzi Industri A/S
Hadsten

MALTA

Carlo Gavazzi Ltd
Zejtun

ITALY

Carlo Gavazzi Controls SpA
Belluno

LITHUANIA

Uab Carlo Gavazzi Industri Kaunas
Kaunas

CHINA

Carlo Gavazzi Automation (Kunshan) Co., Ltd.
Kunshan

HEADQUARTERS

Carlo Gavazzi Automation SpA
Via Milano, 13
I-20045 - Lainate (MI) - ITALY
Tel: +39 02 931 76 1
info@gavazziautomation.com

Energy to Components!

www.gavazziautomation.com